



# RC 120 TOUCH

**POT. TOT. KW**  
4,2 - 12,3

**POT. NOM. KW**  
4 - 11



BIANCO	NERO	BORDEAUX
WHITE	BLACK	BORDEAUX
BLANC	NOIR	BORDEAUX
WEIß	SCHWARZ	BORDEAUX

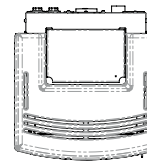
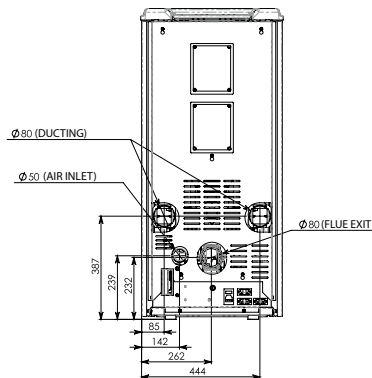
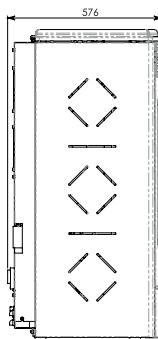
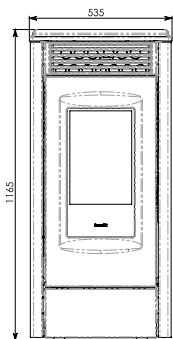
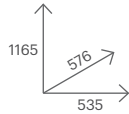

## PELLET

**Consumo orario pellet**  
Pellet fuel consumption for hour  
Consommation de granulés par heure  
Stündlicher Pelletsverbrauch

**kg/h (min/max) 0,8 - 2,5**

**Rendimento min/max potenza**  
Efficiency min/max power  
Rendement min/max puissance  
Wirkungsgrad min/max Leistung

**% 94,4 - 89,5**

**Tubo uscita fumi**  
Flue exit pipe  
Tuyau de sortie des fumées  
Abgasrohr

**Ø mm 80**

**Capacità serbatoio**  
Tank capacity  
Capacité du réservoir  
Fassungsvermögen Pelletsbehälter

**Kg 23**

**Autonomia**  
Burn time  
Autonomie  
Brennzeit

**h 8 - 26**

**Potenza elettrica installata**  
Installed power  
Puissance installée  
Leistungsbedarf beim Betrieb

**W 115**

**Peso netto**  
Net weight  
Poids net  
Nettogewicht

**Kg 195**